

grazia&co melbourne
1 / 10-14 advantage road
highett, vic, 3190
phone +61 3 9555 5760

grazia&co sydney
20 / 108 dunning avenue
rosebery, nsw, 2018
phone +61 2 8914 0350

reeno occasional chair and footstool



australian made 'reeno' occasional chair with optional matching footstool.
upholstered to specification using fr commercial grade foam. released 2016.

grazia&co[®]

plain and perforated vinyl

origin: china



zone vinyl - leather look

origin: usa

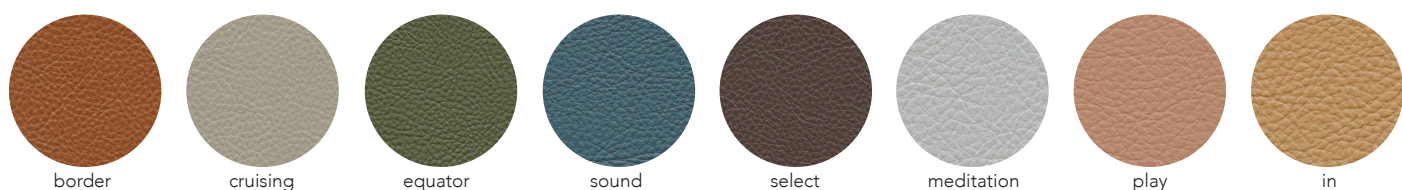

textured vinyl - linen look

origin: europe



koolio vinyl - finely textured, satin look

origin: canada

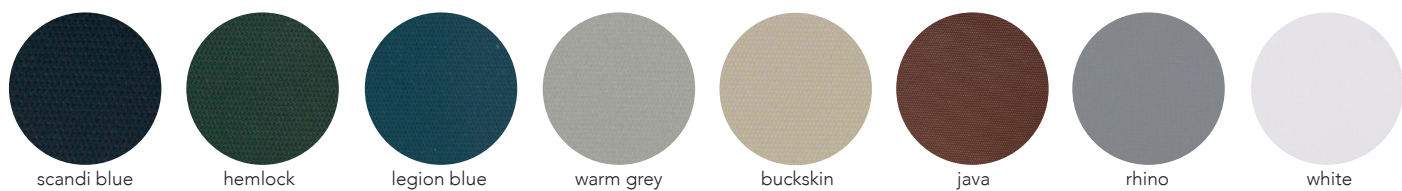

house leather - corrected grain

corrected grain leather
origin: europe

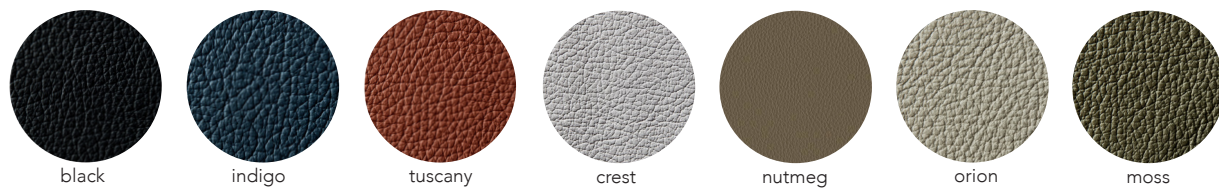

premium leather - semi aniline

semi aniline leather
origin: europe



boucle

composition: 28% acrylic / 24% cotton / 20% viscose / 16% wool / 12% polyester
origin: netherlands
martindale cycles: 80,000

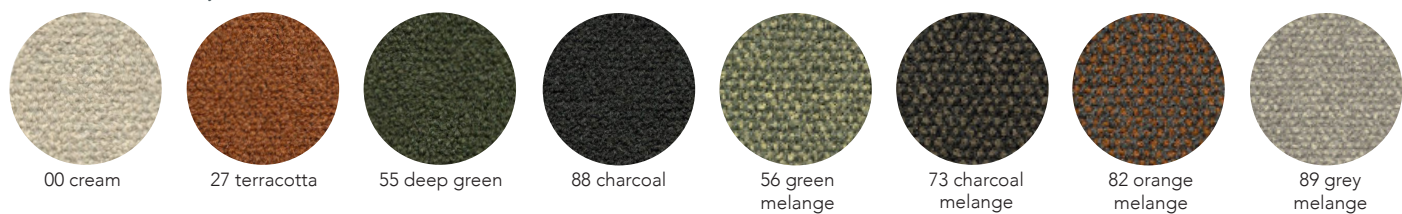

velvet

composition: 39% cotton / 28% alpaca / 11% polyester / 9% wool / 7% nylon / 6% viscose.
origin: italy
martindale cycles: 100,000

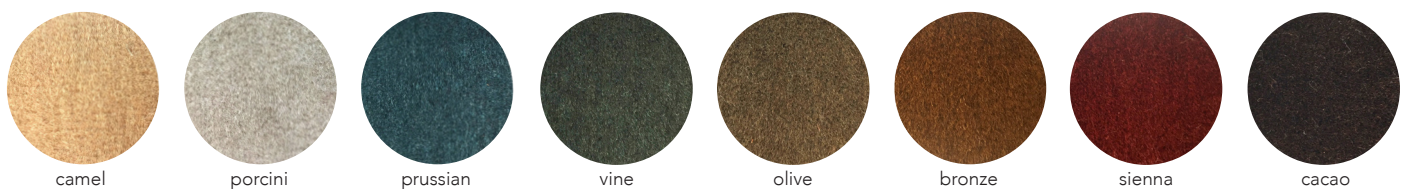

linen weave

composition: 15% linen / 40% cotton / 20% viscose / 20% acrylic / 5% polyester
origin: belgium
matindale cycles: 45,000

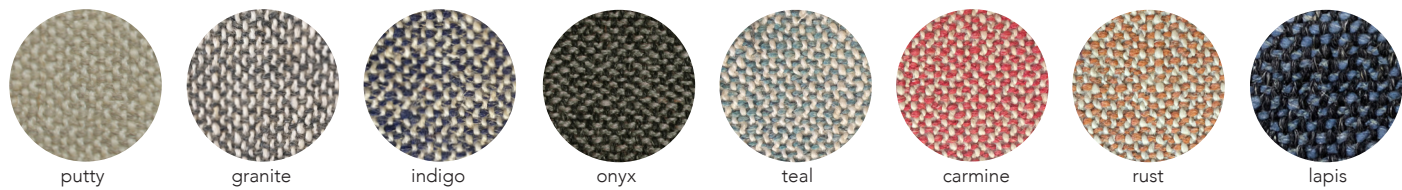

soft textured weave

composition: 100% polyester
origin: netherlands
matindale cycles: 45,000

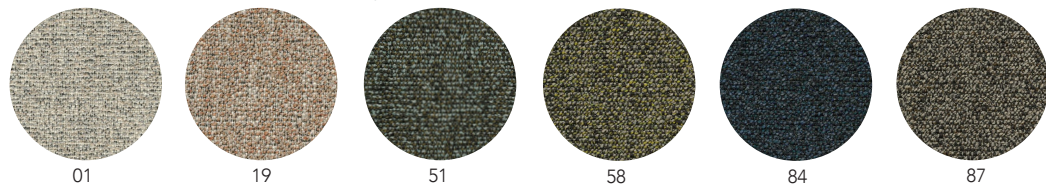

sheepskin

composition: 100% sheepskin wool
origin: australia



custom

custom finishes as specified

1 - chair

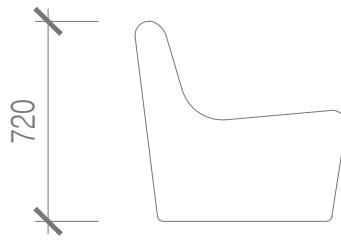
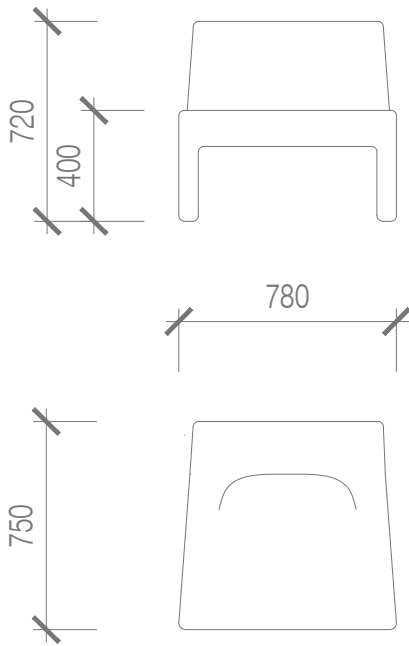

2 - footstool

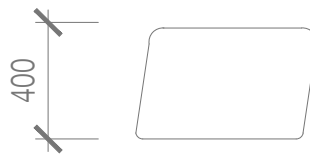
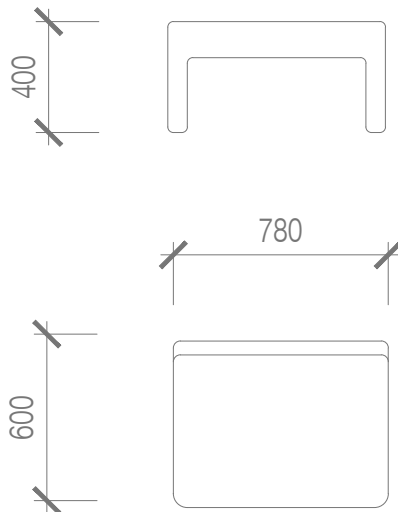

year released
2016

warranty

- i. warranty period of 7 years for the structural integrity of the furniture under "normal use"
- ii. the warranty covers the timber and metal frames, the suspension and the foam integrity.
- iii. fabric and leather wear and tear are not warranted.
- iv. fabric and leather that has faded or broken down due to exposure to sunlight or extreme weather conditions is not warranted.
- v. care instructions and warranty claims of fabric to be addressed with the textile supplier or specifier.
- vi. it is the responsibility of the specifier and/or supplier that has selected and/or supplied a fabric or leather through 3rd party suppliers to ensure it is free of faults and fit for purpose and application.
- vii. leather, sheepskin and other upholsteries with natural compositions can be prone to discolouration due to exposure to sunlight. this is not considered a fault and is not covered by warranty.

all terms outlined in this document are applicable exclusively to projects and orders that are based in australia. for warranty claims outside australia, please note that a 12 month warranty period will apply, all claims are to be taken up with the international selling agent. to view the full warranty please refer to the [grazia&co website](#).

craftmanship: designed and manufactured in australia

materials: mdf frame with foam wrap fully upholstered in specified fabric

lead time: 10-12 weeks. lead times may vary during peak periods

suitability: indoor use



house leather care

protect from direct sunlight, heat and weather. dust with a clean dry cloth or use the soft brush attachment on your vacuum cleaner. remove all liquid and food spills immediately. wipe with a clean cloth dampened with proprietary brand leather cleaner suitable for a surface finish leather.

house vinyl care

maintaining and care of the upholstery should be done by regular vacuuming to remove dust and dirt. spot cleaning should be done immediately after a spill. acid based liquids such as coffee, wine and fruit juice need to be wiped off immediately. the longer a stain or spill remains on the fabric the more difficult it can be to remove. do not use abrasive alcohol based or solvent based cleaners. first spot clean with mild soap and water. using a sponge or very soft bristle brush to remove the stains, rinse with clean water.

velvet

all spills must be actioned right away - blotting the area immediately with a clean, dry absorbent cloth. never bleach, tumble dry, machine wash or iron. have velvet upholstery professionally cleaned according to the velvet suppliers' recommendations. to remove dust, vacuum regularly using low suction and soft brush attachment or using a soft lint brush.

cotton and polyester

protect from direct sunlight. vacuum regularly using low suction and soft brush attachment. professionally clean in accordance to the fabric suppliers' instructions. treat spills and stains as soon as possible with a clean damp cloth. dry in the shade, allow to dry thoroughly before use.

sheepskin

store away from direct sunlight and high heat sources, such as blow dryers and radiators. never rub or brush sheepskin when it's wet. to clean up small spills on your sheepskin upholstery, wipe with a damp cloth, and gently pluck any debris from the suede with tweezers. never use hot water. this causes permanent damage by stripping the natural oil, (lanolin) from the pelt making it very hard and rough. for professional cleaning, select a cleaner that specialises in leather/suede/fur.

custom specified upholstery

please refer to individual suppliers for information on care and maintenance of fabrics that have been specified by a designer, as these will be outside the standard grazia&co range. most interior upholstery fabric should be regularly vacuumed and kept away from direct sunlight.

to view the full care and maintenance please refer to the [grazia&co website](#).



australian
made



no direct
sunlight



do not dry
clean



do not
machine
wash



do not iron